

# EXECUTIVE™ SILENT 275-20



**4000**  
275 BAR  
**PSI**

**20**  
L/PM

**KOHLER KDI1903**  
**42HP**  
**DIESEL**  
**ENGINE TYPE**  
KOHLER Diesel

**DIRECT**  
1500RPM  
**DRIVE**

**HOT**  
**WATER**  
**OUTPUT**



## HERO INNOVATIONS



**PEXO™**  
Enclosed Design



**JWPP™**  
Jetwave Italian Premium Pump



**INTELIUMS™**  
LCD Control System



**OLCE™**  
Oversized Liquid Cooled Engine



**ULDO™**  
Ultra Low Decibel Output



**CLASS A AS/NZS 4203.1**  
HIGH PRESSURE CLEANER  
NOISE CERTIFICATION REQUIRED FOR OPERATORS



## APPLICATIONS

- Industrial Cleaning
- Factories & Manufacturing
- Mine Sites
- Oil & Gas



## STANDOUT FEATURES

JW® UDOR® Premium Italian plunger pump running at 1500RPM direct with soft coupling to the engine, allows longer life and no reduction method.

Sound proof cabinet ensures ultra low noise emissions approx 70dB allowing after hours cleaning in built up areas

Oversized Liquid Cooled Kohler™ KDI1903 42HP diesel engine that optimises all speeds and loads.

Enclosed steel cabinet protection keeps all critical working components safe from weather and operator error.

InteliUMS™ LCD Unit management system displays live data read outs, warnings and auto shutdown to protect the units critical components.

Battery isolator & emergency stop. Lockable diesel fuel fill point for added safety.

## STANDARD EQUIPMENT



**Gun:** J5500k low trigger force gun w/swivel & lance coupling system.

**Lance:** JW Straight stainless steel lance w/ snap coupling + nozzle w/protector & tail



**Hose:** 15m non marking double wire braid hose w/M22 couplings



**Chemical:** JW easy foam kit w/1L bottle



G2 WASHBOX VIDEO

## DIMENSIONS (MM)

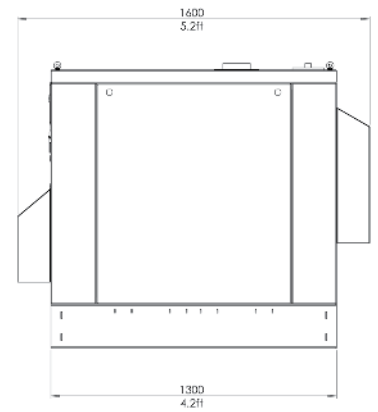

## TECHNICAL DATA 0:00

## EXECUTIVE SILENT 275-20

Product Code	HW4000-20DI
Pressure / Flow Rate	4000 PSI (275 BAR) / 20 L/PM (1200 L/PH) / 5.2 GPM
Max Water Inlet Temp	60°C / 140°F
Class (AS/NZS: 4223)	Class A (5,500 Bar/Litres)
Usage Frequency	Industrial: Continuous Usage
Nozzle Size	05
Frame Structure	CNC Modular skid galvanised steel chassis plus satin powder coat finish w/removable side covers

## MOTOR FEATURES

Engine / Power	Kohler™ KDI1903 Electric Push Button Start (liquid cooled) 42HP / 1861cc
Fuel Type / Capacity / Protection	Diesel / 100L (Common) / IntelliUMS™ Auto Shutdown Protection

## HYDRAULIC FEATURES

Pump / Head / Pistons	JW® UDOR® Premium Triplex Plunger / Brass (Nickle Plated) / Ceramic
Motor Pump Coupling / Pump RPM	Direct Soft Coupling / 1500RPM
Unloader Valve	Independent
Safety Valve	Yes

## HYDRAULIC FEATURES

Burner Model	Vertical 12v High Flow Series
Fuel Supply / Capacity / Consumption	Diesel / 100L / 5.74 L/PH
Coil / Housing Material	Mild steel 3mm wall seamless (500BAR rated) / Zinc coated steel

## DIMENSIONS & WEIGHT

Machine Dimensions / Weight	1400mm(L) x 1100mm(W) x 1270mm(H) / 633KG
-----------------------------	---

## WARRANTY(S)

Unit / Pump Warranty*	 2 Years
Engine Warranty*	<b>KOHLER</b> .Diesel 3 Years

## OPTIONAL ACCESSORIES

JW Pro Turbo Head	JWA303-05
21" Hammerhead FSC - Stainless Steel	JWA-FSC22-5.05

## OPTIONAL UPGRADES

Mine Specification Kit	SILENTMINESPEC
------------------------	----------------

Copyright © 2023 Jetwave® Group Pty Ltd. All Rights Reserved.

The manufacturer reserves the right to modify design features and technical facts without notice, due to our principals of continuous improvement.

\*Coverage against defects in material and workmanship (refer to Jetwave's and component partners T&Cs).

V3.0 08/23