

FEATURES

- Oversized roller bearings
- Fully anodized crankcase
- Innovative new seal design extends seal life
- New plunger design improves thermal shock resistance
- New valve cap improves hydrostatic performance



SPECIFICATIONS

Pump Model	TSF1819	TSF2019	TSF2019 Alternate Spec	TSF2019DS Dual Shaft	TSF2021	TSF2021 Alternate Spec	TSF2219	TSF2219 Alternate Spec	TSF2221	TSF2221 Alternate Spec	TSF2819	TSF2421	TSF2421 Alternate Spec
Maximum Volume	6.3 GPM	7.6 GPM	6.3 GPM	7.6 GPM	8.5 GPM	7.0 GPM	9.3 GPM	7.7 GPM	10.2 GPM	8.5 GPM	12.1 GPM	12.0 GPM	10.0 GPM
Maximum Discharge Pressure	4350 PSI	4000 PSI	4350 PSI	4000 PSI	3600 PSI		3000 PSI				2200 PSI	2500 PSI	3000 PSI
Horsepower	18.8 EBHP	20.8 EBHP	18.7 EBHP	20.8 EBHP	21 EBHP	17.3 BHP	19.1 BHP	15.8 BHP	21 BHP	17.5 BHP	18.2 EBHP	20.5 EBHP	17.1 EBHP
Maximum Pump Speed	1750 RPM		1450 RPM	1750 RPM	1750 RPM	1450 RPM	1750 RPM	1450 RPM	1750 RPM	1450 RPM		1750 RPM	1450 RPM
Maximum Inlet Pressure	125 PSI												
Maximum Inlet Vacuum	9 ft. water / 7.9 in. Hg												
Plunger Bore (in / mm)	.709 in. / 18 mm	.787 in. / 20 mm				.866 in. / 22 mm					1.102 / 28 mm	.945 / 24 mm	
Plunger Stroke (in / mm)	.748 in. / 19 mm				.826 in. / 21 mm		.748 / 19		.826 in / 21 mm		.748 / 19 mm		.826 in / 21 mm
Oil Capacity	37.2 oz.												
Maximum Fluid Temperature	165° F												
Inlet Port Thread	3/4"-14 BSP-F												
Discharge Port Thread	3/8"-19 BSP-F												
Shaft Diameter (in / mm)	.945 in. / 24 mm												
Weight	40.7 lbs / 18.5 kg												
Dimensions	14.94" x 9.78" x 6.99"												

TRIPLEX

TRIPLEX



General Pump is a member of the Interpump Group



Ref 310045 Rev. N
04-19



66 Series, TSF

GENERAL PUMP

A member of the Interpump Group

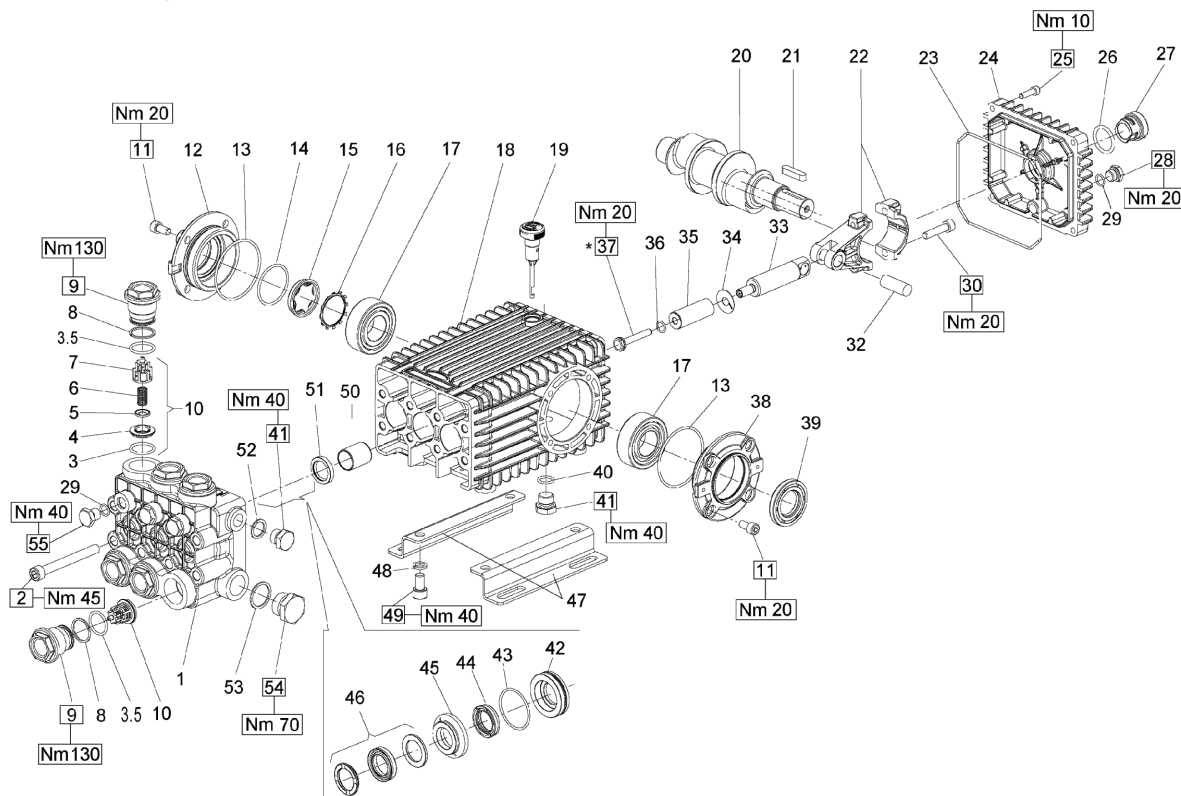

PARTS LIST

POS.	PART NO.	DESCRIPTION	QTY.	POS.	PART NO.	DESCRIPTION	QTY.	POS.	PART NO.	DESCRIPTION	QTY.
1	66124541	Manifold, Ø 18mm	1	21	91489200	Key, 9x7x35	1	42	66080470	Seal Retainer, Ø 24mm	3
	66120041	Manifold, Ø 20mm	1	22	66030001	Connecting Rod, Complete	3		66082570	Seal Retainer, Ø 28mm	3
	66120141	Manifold, Ø 22 mm	1	23	90392200	O-ring, Ø133.02x2.62	1	43	90361600	O-ring, Ø 34.65x1.78	3
	66120241	Manifold, Ø 24mm	1	24	66160022	Rear Cover	1	44	90265200	LP Seal, Ø 18mm	3
	66124641	Manifold, Ø 28mm	1	25	99188400	Screw, M6x20	4		90269000	LP Seal, Ø 20mm	3
2	99380100	Headbolt M10 x 90	8	26	90405100	O-ring, 26.58x3.53	1		90271500	LP Seal, Ø 22mm	3
3	90385700	O-ring, Ø 23.81x2.62	6	27	63210051	Oil Level Indicator	1		90273800	LP Seal, Ø 24mm	3
3.5	90385700	O-ring, Ø 23.81x2.62	6	28	98204100	Plug, G1/4"x9	1		90275300	LP Seal, Ø 28mm	3
4	36203366	Valve Seat	6	29	701013	O-ring, Ø 426x.070	4	45	66216370	Intermediate Ring, Ø 18mm	3
5	36203476	Valve Poppet	6	30	99309900	Screw, M8x35	6		66216070	Intermediate Ring, Ø 20mm	3
6	94738800	Valve Spring Ø10x18x18.5	6	32	97740500	Wrist Pin, 14x39	3		66216170	Intermediate Ring, Ø 22mm	3
7	36203551	Valve Guide	6	33	66050066	Piston Guide	3		66216470	Intermediate Ring, Ø 24mm	3
8	90516500	Anti-ext ring Ø24.7x29x1.5	6	34	96710100	Flinger Washer	3		66220070	Intermediate Ring, Ø 28mm	3
9	66130041	Plug, M32x1.5x29.5	6	35	66040309	Plunger, Ø 18mm	3	46	90265500	HP Seal, Ø 18mm	3
10	36712701	Valve Assy., Complete	6		66040009	Plunger, Ø 20mm	3		90269200	HP Seal, Ø 20mm	3
11	99303900	Screw M8 x 16	8		66040109	Plunger, Ø 22 mm	3		90271700	HP Seal, Ø 22mm	3
12	47151222	Cover	1		66040409	Plunger, Ø 24mm	3		90274100	HP Seal, Ø 24mm	3
13	701147	O-ring, Ø67.95x2.62	2		66041009	Plunger, Ø 28mm	3		90275400	HP Seal, Ø 28mm	3
14	90387700	O-ring, Ø 39.34x2.62	1	36	90358400	O-ring, Ø 10.82x1.78	3	47	47200074	Pump Rail	2
15	70211801	Oil Sight Glass	1	37	66219566	Plunger Bolt	3	48	96710600	Washer M10	4
16	90075600	Retainer Clip	1	38	47151022	Side Cover, PTO	1	49	99364400	Screw M10 x 18	4
17	91838000	Bearing	2	39	90164800	Seal, Shaft	1	50	90912600	Guide Bushing	3
18	66010022	Crankcase	1	40	90383300	O-ring, Ø 13.95x2.62	1	51	90162500	Seal, Plunger Rod	3
19	98210600	Dipstick, vented	1	41	98210000	Plug 3/8 x 13	2	52	96738000	Gasket, Aluminum 3/8"	1
20	66021035	Crankshaft, 19mm Stroke, 1 Dual Shaft	1	42	66080370	Seal Retainer, Ø 18mm	3	53	96770000	Washer	1
	66020035	Crankshaft, 19mm Stroke	1		66080070	Seal Retainer, Ø 20mm	3	54	98226800	Plug, G3/4"x16	1
	66020435	Crankshaft, 21mm Stroke	1		66080170	Seal Retainer, Ø 22mm	3	55	98204300	Plug 1/4" x 13	3

REPAIR KITS

KIT NO.	K02	K03	K169	K180 (18mm)	K176 (18mm)	K170 (20mm)	K171 (20mm)	K172 (22mm)	K173 (22mm)	K181 (24 mm)	K182 (24mm)	K248 (28mm)	K247 (28mm)
POS. NO's INCLUDED IN KIT	51	39	3, 4, 5, 6, 7 (10)	44, 46	42, 43, 44, 45, 46	44, 46	42, 43, 44, 45, 46	44, 46	42, 43, 44, 45, 46	44, 46	42, 43, 44, 45, 46	44, 46	42, 43, 44, 45, 46
NUMBER OF ASSEMBLIES IN KIT	3	1	6	3	1	3	1	3	1	3	1	3	1
NUMBER OF CYLINDERS KIT WILL SERVICE	3	N/A	3	3	1	3	1	3	1	3	1	3	1

66 Series, TSF

GENERAL PUMP

A member of the Interpump Group

DIMENSIONAL DRAWING

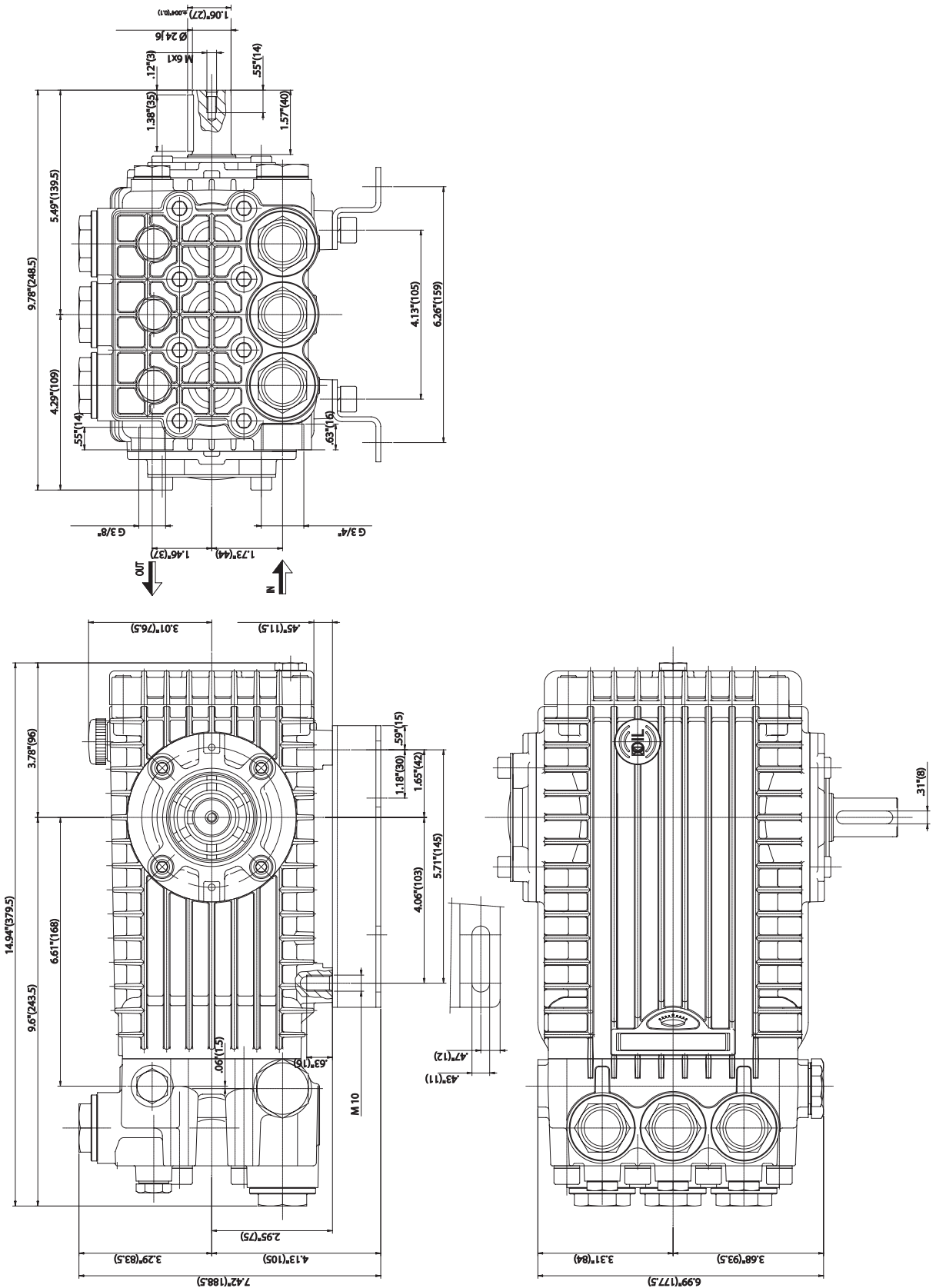

TORQUE SPECS*

POS.	Nm	Ft/lb
2	45	33.2
9	130	95.9
11	20	14.8
25	10	7.4
28	20	14.8
30	20	14.8
37**	20	14.8†
41	40	29.5
49	40	29.5
54	70	51.6
55	40	29.5

* Decrease torque by 20% if threads are lubricated

** Use Loc-Tite 542 or similar

OIL CHANGING

1. Oil changing must be done with the pump at operating temperature.
- 1.2 Put a container under the oil drain plug (3).
- 1.3 Remove the oil dipstick (1) and then the drain plug (3).
- 1.4 Wait until all the oil has drained out, then screw the drain plug (3) and tighten at the torque shown in the exploded diagram and above table.
- 1.5 Fill with new oil (General Pump Series 100) until the middle of the oil sight glass is reached, screw by hand the oil dipstick (1).

